

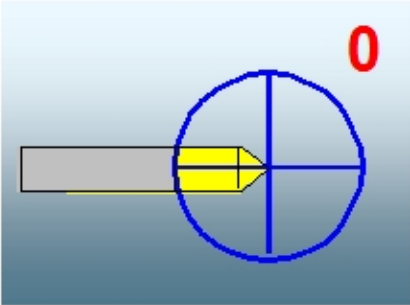

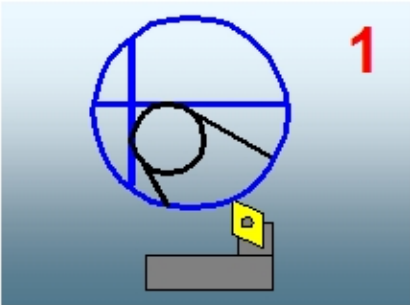
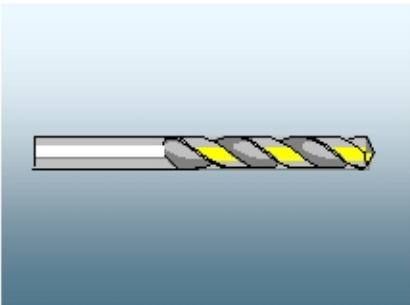
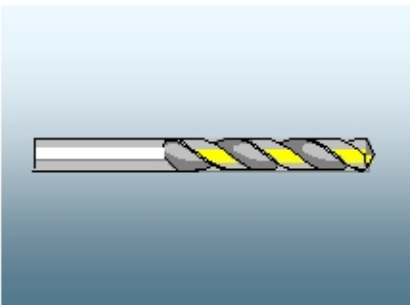
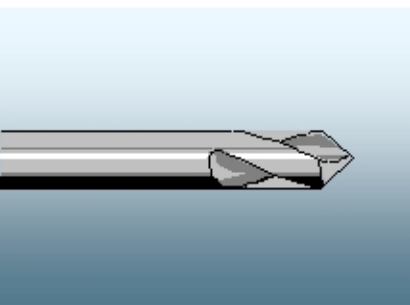
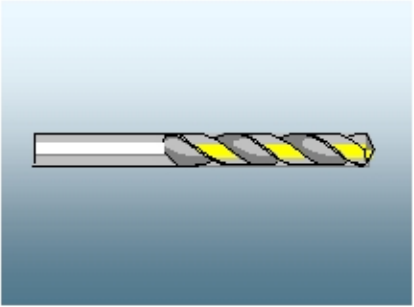
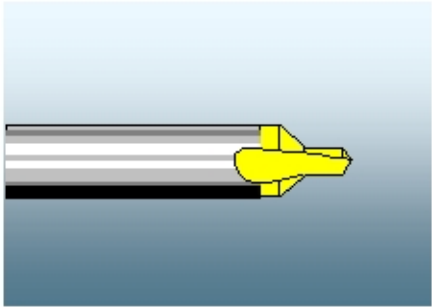
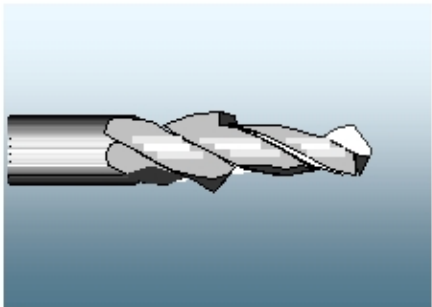
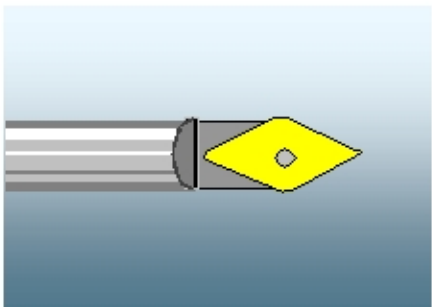
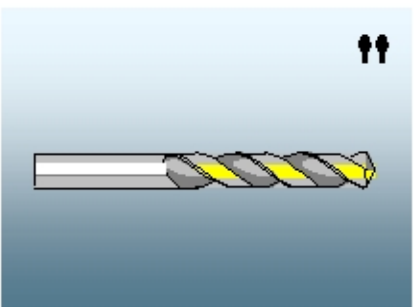

Group details

DATOS	Upper group 65637	Position 10	ID 65644	
0	is Active ✓	Is Upper Group ✓		
DATOS	Upper group 65637	Position 1	ID 65641	
1	is Active ✓	Is Upper Group		
DATOS	Upper group 65537	Position 1	ID 65605	
1 - drill	is Active ✓	Is Upper Group ✓		
DATOS	Upper group 65605	Position 1	ID 65634	
11 - drill	is Active ✓	Is Upper Group ✓		
DATOS	Upper group 65634	Position 1	ID 65639	
111 - spot drill	is Active ✓	Is Upper Group		

Group details

DATOS	Upper group 65634	Position 2	ID 65651	
112 - twist drill				
112				
	is Active ✓	Is Upper Group ✓		
DATOS	Upper group 65634	Position 3	ID 65610	
113 - center drill				
113				
	is Active ✓	Is Upper Group		
DATOS	Upper group 65634	Position 4	ID 65613	
114 - step drill				
114				
	is Active ✓	Is Upper Group		
DATOS	Upper group 65605	Position 2	ID 65652	
12 - insert drill				
12				
	is Active ✓	Is Upper Group ✓		
DATOS	Upper group 65605	Position 3	ID 65659	
13 - "drill				
13				
	is Active ✓	Is Upper Group ✓		

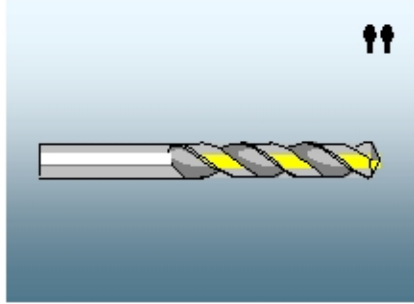
Group details

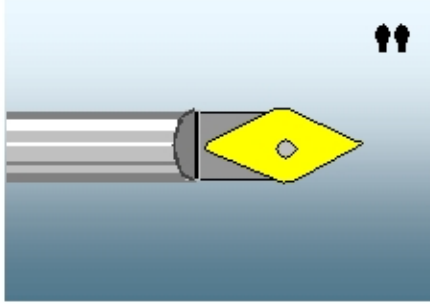
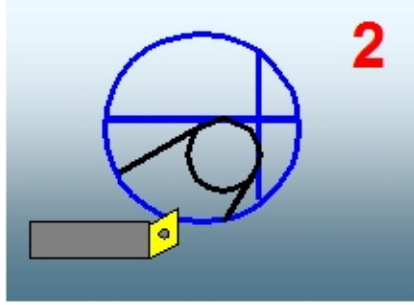
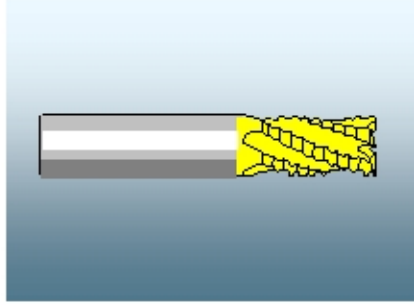
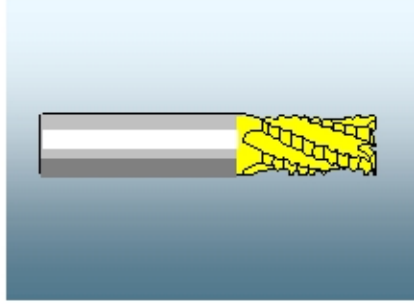
DATOS	Upper group 65659	Position 2	ID 65684	
132 - inch twist drills				
	is Active ✓	Is Upper Group		
DATOS	Upper group 65659	Position 8	ID 65685	
138 - inch insert drills				
	is Active ✓	Is Upper Group		
DATOS	Upper group 65637	Position 2	ID 65620	
2				
	is Active ✓	Is Upper Group		
DATOS	Upper group 65537	Position 2	ID 65653	
2 - mill				
2				
	is Active ✓	Is Upper Group ✓		
DATOS	Upper group 65653	Position 1	ID 65539	
21 - end mill				
21				
	is Active ✓	Is Upper Group ✓		

Group details

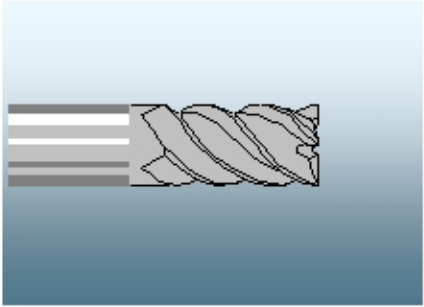
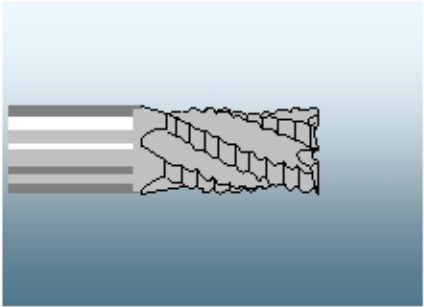
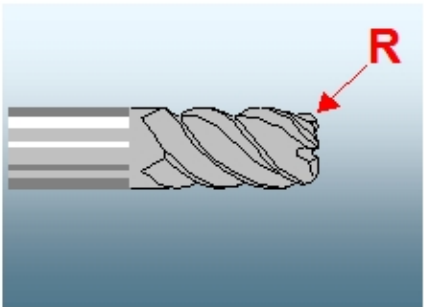
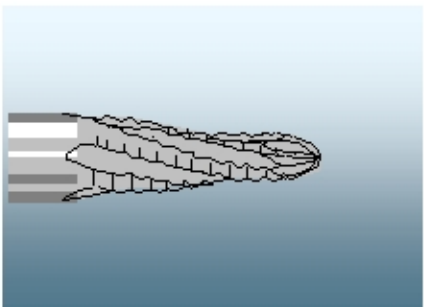
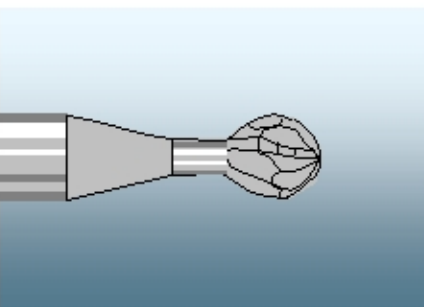
DATOS	Upper group 65539	Position 1	ID 65621	
211 - end mill finishing				
211				
	is Active ✓		Is Upper Group	
DATOS	Upper group 65539	Position 2	ID 65554	
212 - end mill roughing				
212				
	is Active ✓		Is Upper Group	
DATOS	Upper group 65539	Position 4	ID 65628	
214 - bull nose end mill				
214				
	is Active ✓		Is Upper Group	
DATOS	Upper group 65539	Position 5	ID 65680	
215 - conical mill				
215				
	is Active ✓		Is Upper Group	
DATOS	Upper group 65539	Position 6	ID 65681	
216 - Lollipop mill				
216				
	is Active ✓		Is Upper Group	

Group details

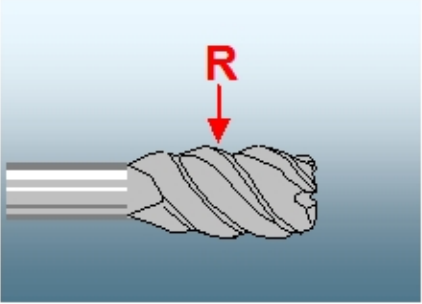
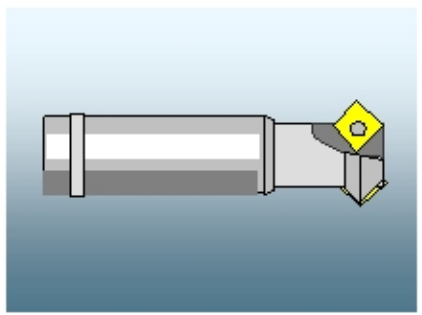
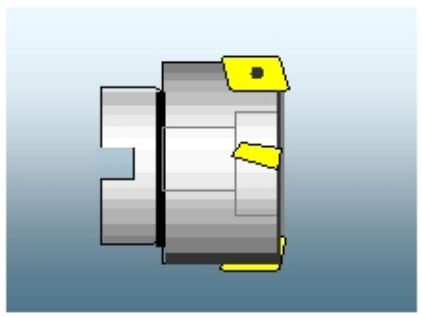
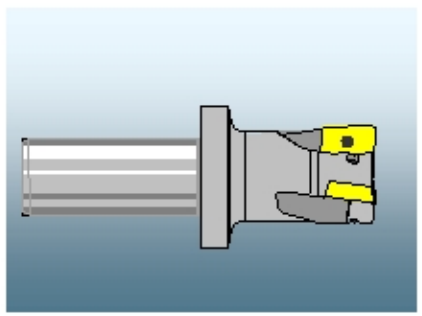
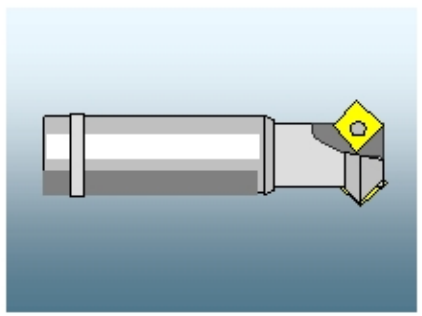
DATOS	Upper group 65539	Position 7	ID 65683	
217 - barell mill				
217				
	is Active ✓		Is Upper Group	
DATOS	Upper group 65653	Position 2	ID 65578	
22 - insert mill				
22				
	is Active ✓		Is Upper Group ✓	
DATOS	Upper group 65578	Position 1	ID 65555	
221 - face mill				
221				
	is Active ✓		Is Upper Group	
DATOS	Upper group 65578	Position 2	ID 65609	
222 - square shoulder cutter				
222				
	is Active ✓		Is Upper Group	
DATOS	Upper group 65578	Position 3	ID 65553	
223 - chamfer mill				
223				
	is Active ✓		Is Upper Group	

Group details

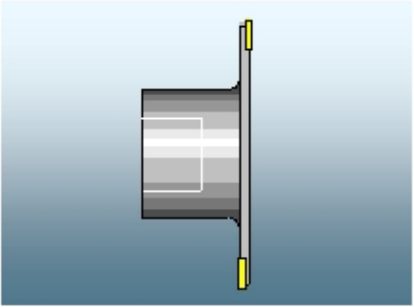
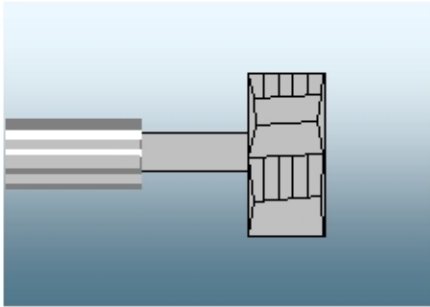
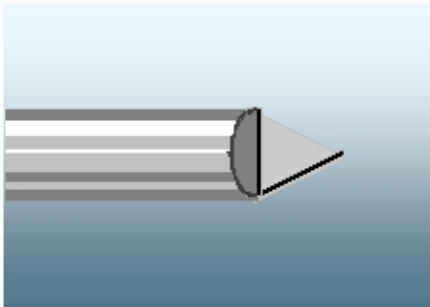
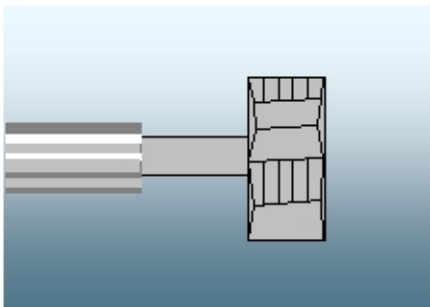
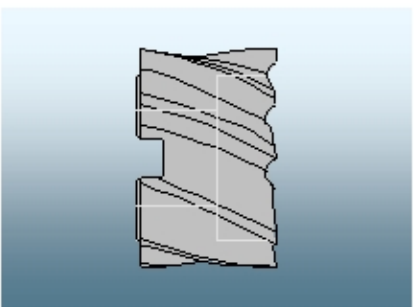
DATOS	Upper group 65578	Position 4	ID 65611	
224 - disk mill				
224				
	is Active ✓	Is Upper Group		
DATOS	Upper group 65653	Position 4	ID 65654	
24 - other mills				
24				
	is Active ✓	Is Upper Group ✓		
DATOS	Upper group 65654	Position 1	ID 65640	
241 - engraving tool				
241				
	is Active ✓	Is Upper Group		
DATOS	Upper group 65654	Position 2	ID 65629	
242 - T-slot milling cutter				
242				
	is Active ✓	Is Upper Group		
DATOS	Upper group 65654	Position 3	ID 65552	
243 - shell mill				
243				
	is Active ✓	Is Upper Group		

Group details

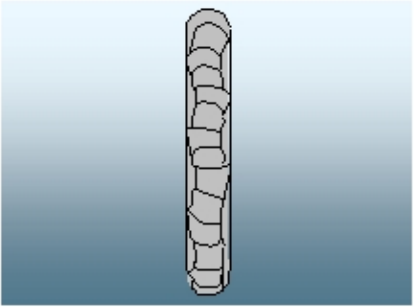
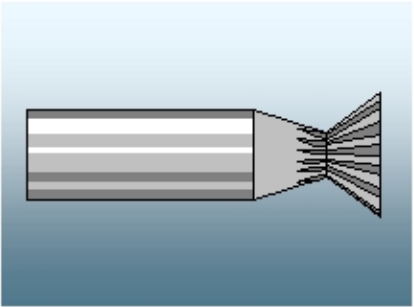
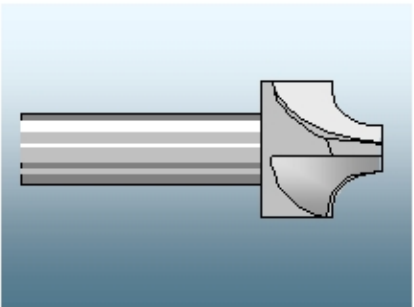
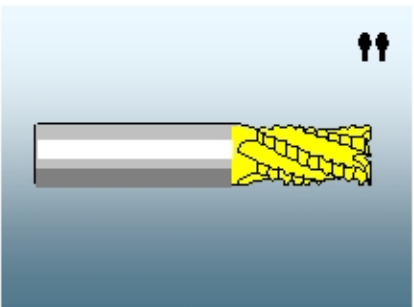
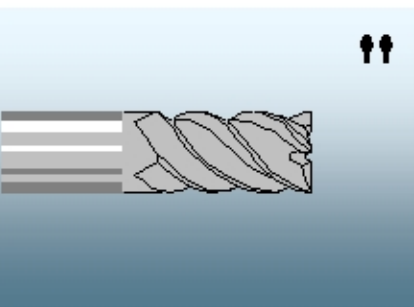
DATOS	Upper group 65654	Position 4	ID 65568	
244 - half circle cutter				
244				
	is Active ✓		Is Upper Group	
DATOS	Upper group 65654	Position 5	ID 65603	
245 - dovetail mill				
245				
	is Active ✓		Is Upper Group	
DATOS	Upper group 65654	Position 6	ID 65682	
246 - Quarter round mill				
246				
	is Active ✓		Is Upper Group	
DATOS	Upper group 65653	Position 6	ID 65615	
25 - "end mill				
25				
	is Active ✓		Is Upper Group ✓	
DATOS	Upper group 65615	Position 1	ID 65686	
251 - "end mill finishing				
251				
	is Active ✓		Is Upper Group	

Group details

DATOS	Upper group 65653	Position 7	ID 65671	
26 - "insert mill"				
26				
	is Active ✓		Is Upper Group ✓	
DATOS	Upper group 65671	Position 1	ID 65687	
261 - "face mill"				
261				
	is Active ✓		Is Upper Group	
DATOS	Upper group 65653	Position 8	ID 65563	
27 - "other mills"				
27				
	is Active ✓		Is Upper Group ✓	
DATOS	Upper group 65563	Position 5	ID 65688	
275 - "Dovetail mill"				
275				
	is Active ✓		Is Upper Group	
DATOS	Upper group 65637	Position 3	ID 65624	
3				
3				
	is Active ✓		Is Upper Group	

Group details

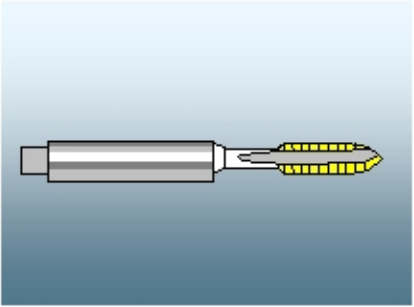
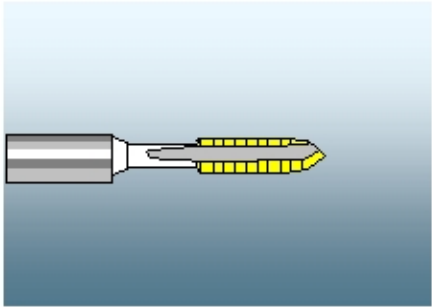
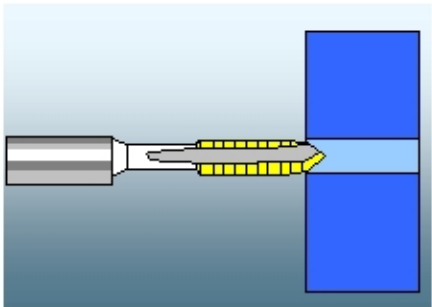
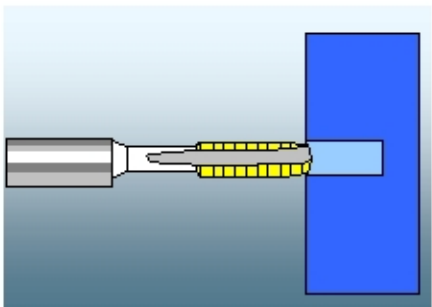
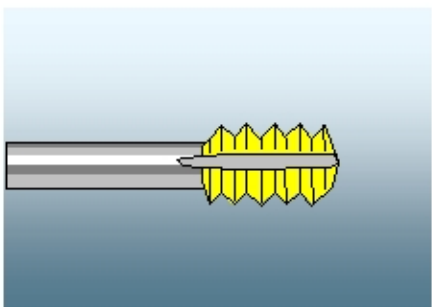
DATOS	Upper group 65537	Position 3	ID 65542	
3 - tap				
3				
	is Active ✓	Is Upper Group ✓		
DATOS	Upper group 65542	Position 1	ID 65655	
31 - tap				
31				
	is Active ✓	Is Upper Group ✓		
DATOS	Upper group 65655	Position 1	ID 65656	
311 - tap metric				
311				
	is Active ✓	Is Upper Group ✓		
DATOS	Upper group 65655	Position 3	ID 65657	
312 - tap metric blind hole				
312				
	is Active ✓	Is Upper Group ✓		
DATOS	Upper group 65542	Position 2	ID 65658	
32 - tap other				
32				
	is Active ✓	Is Upper Group ✓		

Group details

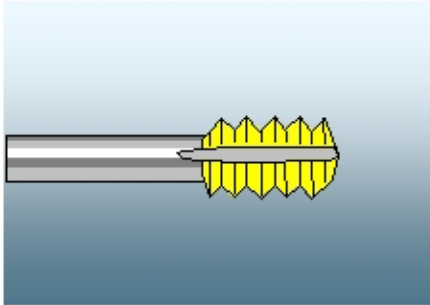
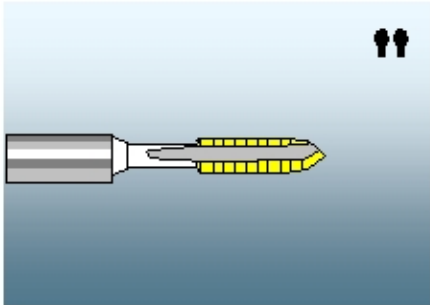
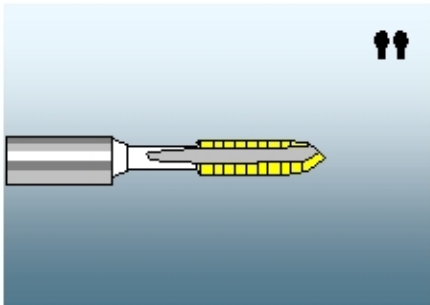
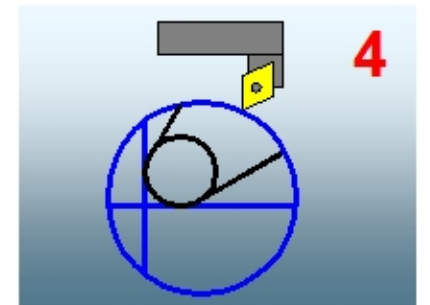
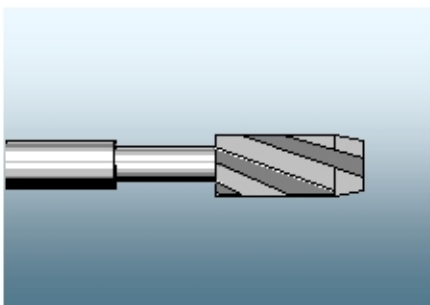
DATOS	Upper group 65658	Position 1	ID 65612	
321 - thread mill				
321				
	is Active ✓	Is Upper Group		
DATOS	Upper group 65542	Position 3	ID 65663	
33 - "tap				
33				
	is Active ✓	Is Upper Group ✓		
DATOS	Upper group 65663	Position 1	ID 65689	
331 - "tap				
331				
	is Active ✓	Is Upper Group		
DATOS	Upper group 65637	Position 4	ID 65618	
4				
	is Active ✓	Is Upper Group		
DATOS	Upper group 65537	Position 4	ID 65660	
4 - reamer, c.bore				
4				
	is Active ✓	Is Upper Group ✓		

Group details

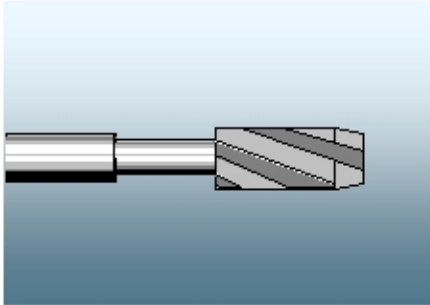
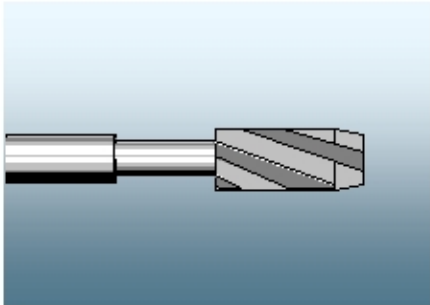
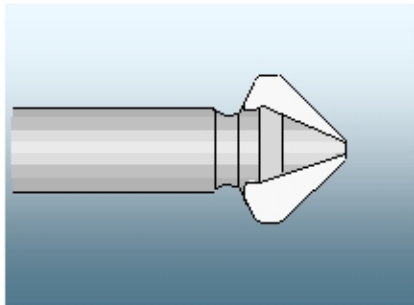
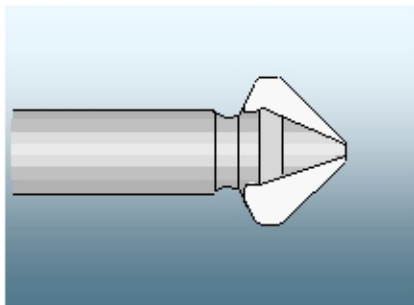
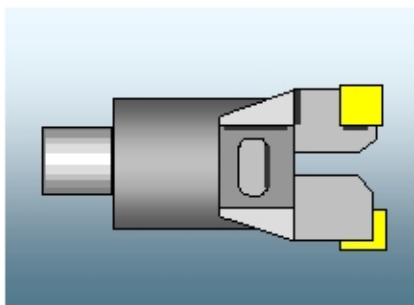
DATOS	Upper group 65660	Position 1	ID 65661	
41 - reamer				
41				
	is Active ✓		Is Upper Group ✓	
DATOS	Upper group 65661	Position 1	ID 65557	
411 - reamer cylindrical				
411				
	is Active ✓		Is Upper Group	
DATOS	Upper group 65660	Position 2	ID 65662	
42 - counterbore				
42				
	is Active ✓		Is Upper Group ✓	
DATOS	Upper group 65662	Position 2	ID 65559	
422 - countersinks				
422				
	is Active ✓		Is Upper Group	
DATOS	Upper group 65537	Position 5	ID 65561	
5 - modular system				
5				
	is Active ✓		Is Upper Group ✓	

Group details

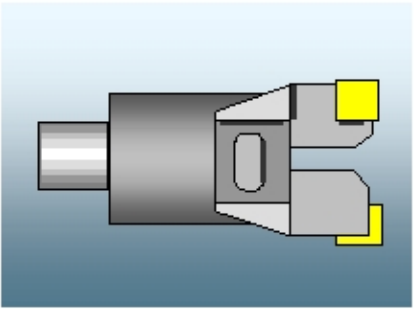
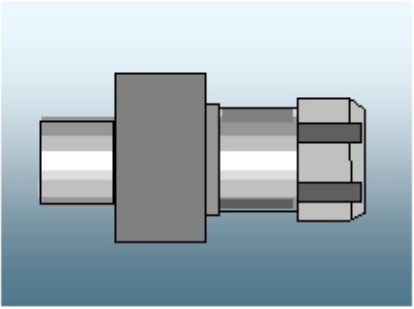
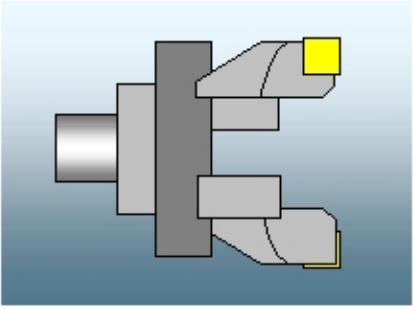
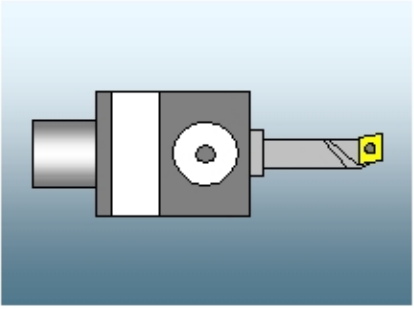
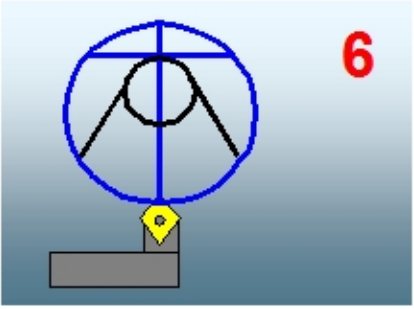
DATOS	Upper group 65561	Position 1	ID 65670	
51 - System type A				
51				
	is Active ✓	Is Upper Group ✓		
DATOS	Upper group 65670	Position 1	ID 65582	
511 - holder modular A				
511				
	is Active ✓	Is Upper Group ✓		
DATOS	Upper group 65670	Position 2	ID 65676	
512 - boring head A				
	is Active ✓	Is Upper Group ✓		
DATOS	Upper group 65670	Position 3	ID 65672	
513 - boring bar A				
513				
	is Active ✓	Is Upper Group ✓		
DATOS	Upper group 65637	Position 6	ID 65619	
6				
	is Active ✓	Is Upper Group		

Group details

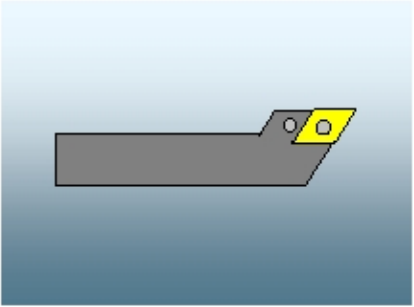
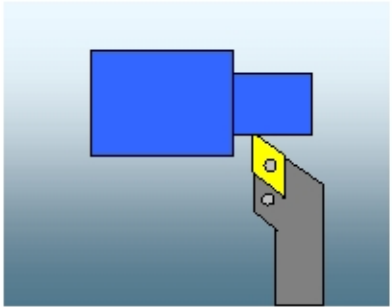
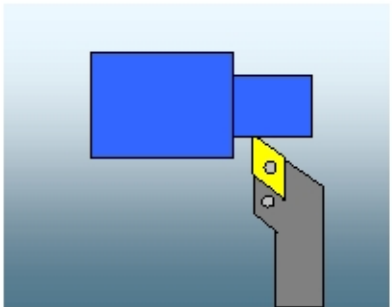
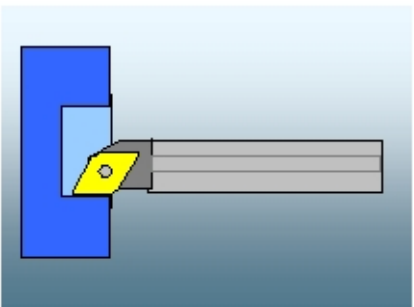
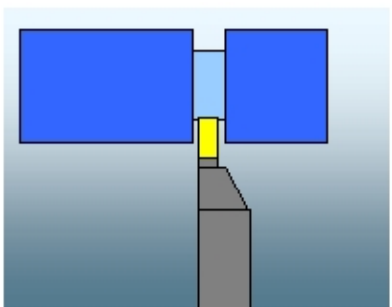
DATOS	Upper group 65537	Position 6	ID 65541	
6 - turning tool				
6				
	is Active ✓	Is Upper Group ✓		
DATOS	Upper group 65541	Position 1	ID 65673	
61 - turning				
61				
	is Active ✓	Is Upper Group ✓		
DATOS	Upper group 65673	Position 1	ID 65576	
611 - turning tool outside				
611				
	is Active ✓	Is Upper Group		
DATOS	Upper group 65673	Position 2	ID 65631	
612 - turning tool inside				
612				
	is Active ✓	Is Upper Group		
DATOS	Upper group 65541	Position 2	ID 65674	
62 - grooving				
62				
	is Active ✓	Is Upper Group ✓		

Group details

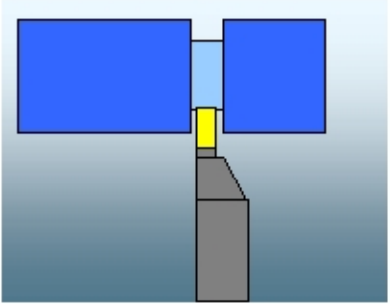
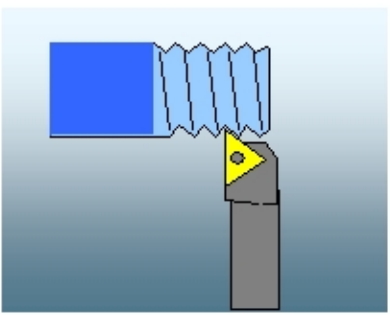
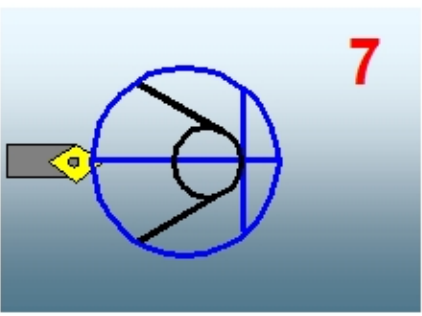
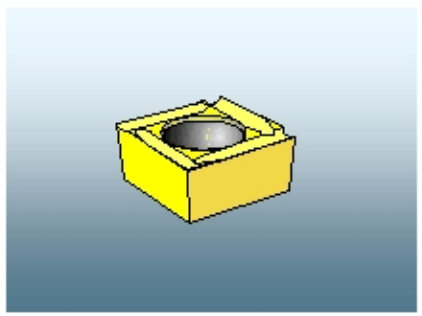
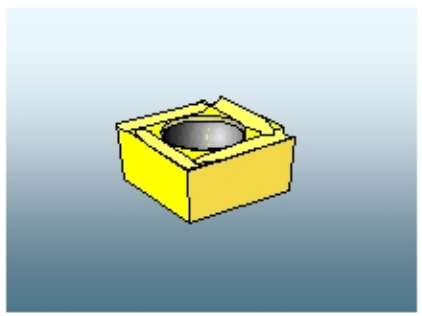
DATOS	Upper group 65674	Position 1	ID 65632	
621 - grooving tool outside				
621				
	is Active ✓	Is Upper Group		
DATOS	Upper group 65541	Position 3	ID 65675	
63 - thread				
63				
	is Active ✓	Is Upper Group ✓		
DATOS	Upper group 65637	Position 7	ID 65623	
7				
	is Active ✓	Is Upper Group		
DATOS	Upper group 65537	Position 7	ID 65664	
7 - insert				
7				
	is Active ✓	Is Upper Group ✓		
DATOS	Upper group 65664	Position 1	ID 65540	
71 - inserts				
71				
	is Active ✓	Is Upper Group ✓		

Group details

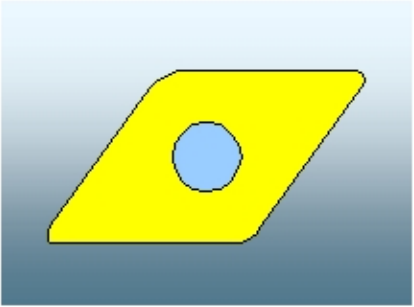
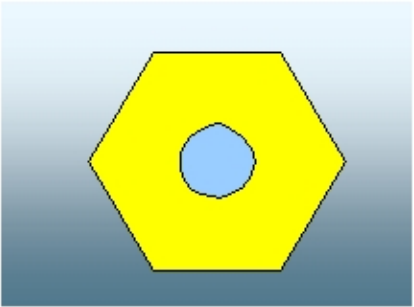
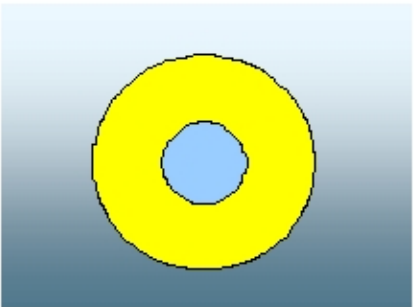
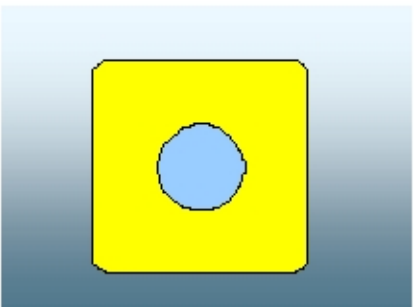
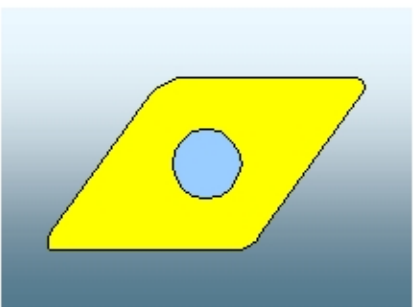
DATOS	Upper group 65540	Position 1	ID 65583	
711 - insert form C				
711				
	is Active ✓	Is Upper Group		
DATOS	Upper group 65540	Position 2	ID 65614	
712 - insert form D				
712				
	is Active ✓	Is Upper Group		
DATOS	Upper group 65540	Position 5	ID 65596	
715 - insert form R				
715				
	is Active ✓	Is Upper Group		
DATOS	Upper group 65540	Position 6	ID 65597	
716 - insert form S				
716				
	is Active ✓	Is Upper Group		
DATOS	Upper group 65540	Position 8	ID 65649	
718 - insert form V				
718				
	is Active ✓	Is Upper Group		

Group details

DATOS	Upper group 65540	Position 9	ID 65562	
719 - other inserts				
719	is Active ✓	Is Upper Group		
DATOS	Upper group 65664	Position 2	ID 65665	
72 - grooving blade				
72	is Active ✓	Is Upper Group ✓		
DATOS	Upper group 65665	Position 1	ID 65602	
721 - insert grooving				
721	is Active ✓	Is Upper Group		
DATOS	Upper group 65664	Position 3	ID 65667	
73 - insert thread				
73	is Active ✓	Is Upper Group ✓		
DATOS	Upper group 65664	Position 4	ID 65690	
74 - "inserts"				
74	is Active ✓	Is Upper Group ✓		

Group details

DATOS	Upper group 65690	Position 1	ID 65691	
741 - "insert form C"				
741				
	is Active ✓		Is Upper Group	
DATOS	Upper group 65637	Position 8	ID 65622	
8				
	is Active ✓		Is Upper Group	
DATOS	Upper group 65537	Position 8	ID 65668	
8 - holder				
8				
	is Active ✓		Is Upper Group ✓	
DATOS	Upper group 65668	Position 1	ID 65591	
81 - rotating				
81				
	is Active ✓		Is Upper Group ✓	
DATOS	Upper group 65591	Position 1	ID 65569	
811 - shell mill holder				
811				
	is Active ✓		Is Upper Group	

Group details

DATOS	Upper group 65591	Position 2	ID 65595	
812 - end mill holder fl.driv.				
812				
	is Active ✓		Is Upper Group	
DATOS	Upper group 65591	Position 5	ID 65679	
815 - shrink fit holder				
815				
	is Active ✓		Is Upper Group	
DATOS	Upper group 65591	Position 6	ID 65566	
816 - collet chuck ER				
816				
	is Active ✓		Is Upper Group	
DATOS	Upper group 65591	Position 7	ID 65565	
817 - drill holder				
817				
	is Active ✓		Is Upper Group	
DATOS	Upper group 65591	Position 8	ID 65564	
818 - tap holder				
818				
	is Active ✓		Is Upper Group	

Group details

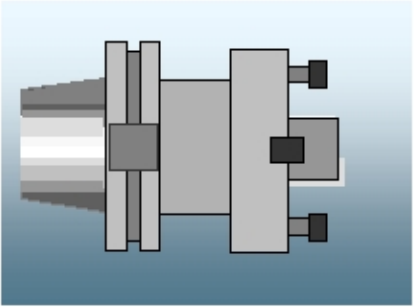
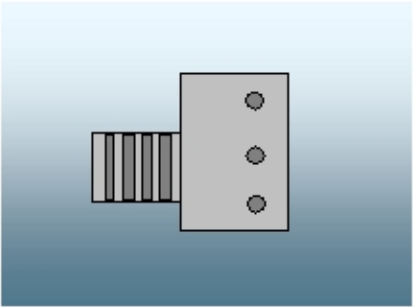
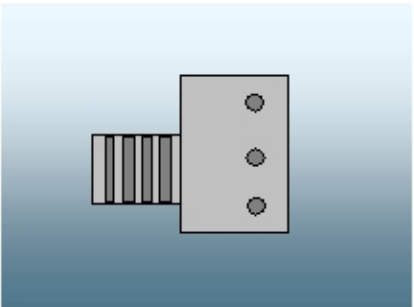
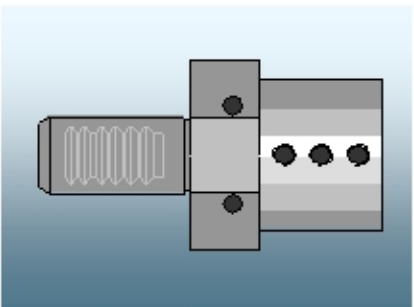
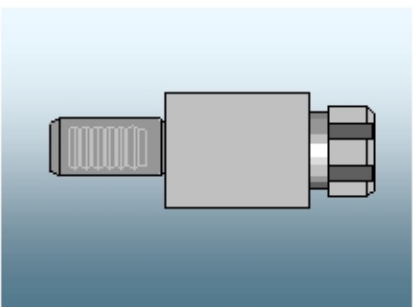
DATOS	Upper group 65591	Position 9	ID 65638	
819 - other rotating holder				
819				
	is Active ✓	Is Upper Group		
DATOS	Upper group 65668	Position 2	ID 65616	
82 - stillstanding				
82				
	is Active ✓	Is Upper Group ✓		
DATOS	Upper group 65616	Position 1	ID 65630	
821 - turning tool holder				
821				
	is Active ✓	Is Upper Group		
DATOS	Upper group 65616	Position 2	ID 65678	
822 - boring bar holder				
822				
	is Active ✓	Is Upper Group		
DATOS	Upper group 65616	Position 3	ID 65677	
823 - collet chuck f. turning				
823				
	is Active ✓	Is Upper Group		

Group details

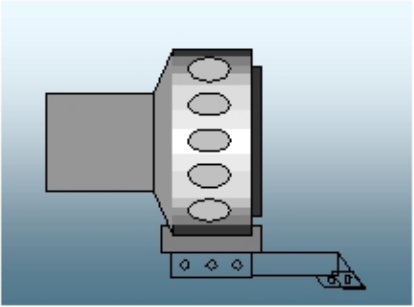
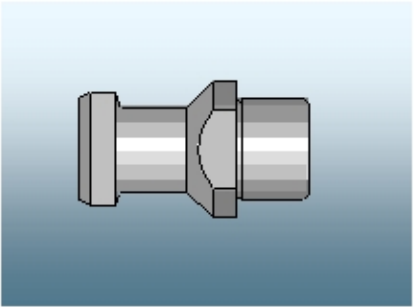
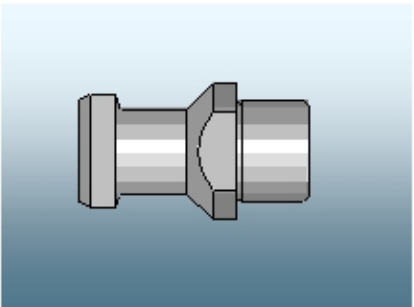
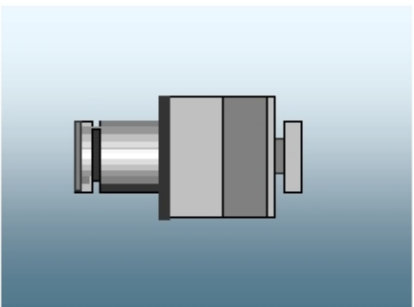
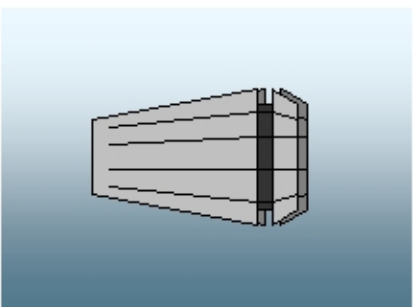
DATOS	Upper group 65616	Position 5	ID 65648	
825 - Revolver Drehmaschine				
825				
	is Active ✓	Is Upper Group		
DATOS	Upper group 65668	Position 3	ID 65669	
83 - accessory				
83				
	is Active ✓	Is Upper Group ✓		
DATOS	Upper group 65669	Position 1	ID 65575	
831 - revolvers				
831				
	is Active ✓	Is Upper Group		
DATOS	Upper group 65669	Position 2	ID 65574	
832 - pull-studs				
832				
	is Active ✓	Is Upper Group		
DATOS	Upper group 65669	Position 3	ID 65573	
833 - collets				
833				
	is Active ✓	Is Upper Group		

Group details

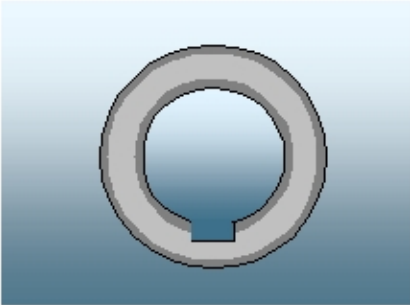
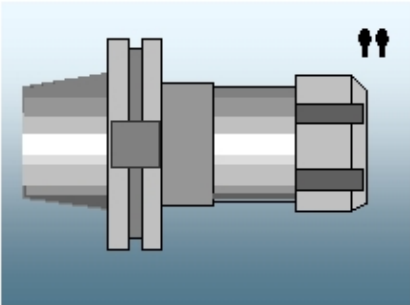
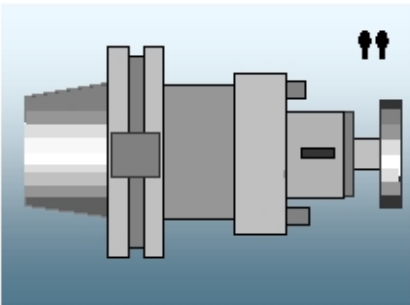
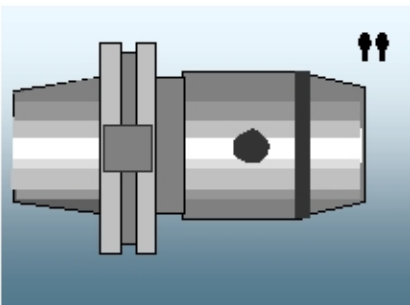
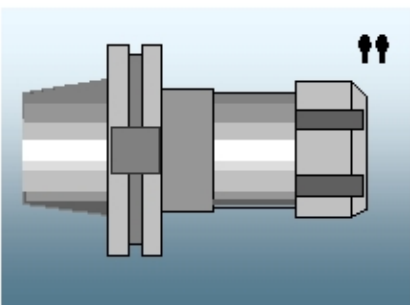
DATOS	Upper group 65669	Position 4	ID 65571	
835 - shell mill holder ring				
	is Active ✓	Is Upper Group		
DATOS	Upper group 65668	Position 4	ID 65692	
84 - " holder				
84				
	is Active ✓	Is Upper Group ✓		
DATOS	Upper group 65692	Position 1	ID 65693	
841 - "shell mill holder				
841				
	is Active ✓	Is Upper Group		
DATOS	Upper group 65692	Position 2	ID 65694	
842 - "end mill holder				
842				
	is Active ✓	Is Upper Group		
DATOS	Upper group 65692	Position 6	ID 65695	
846 - "collets				
846				
	is Active ✓	Is Upper Group		

Group details

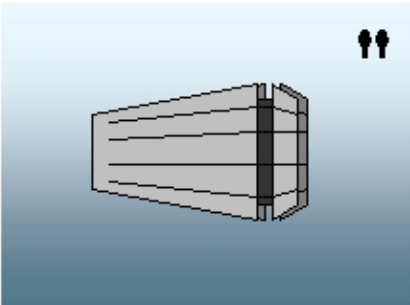
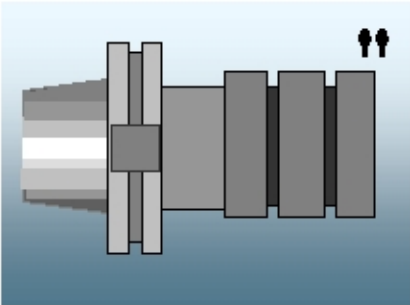
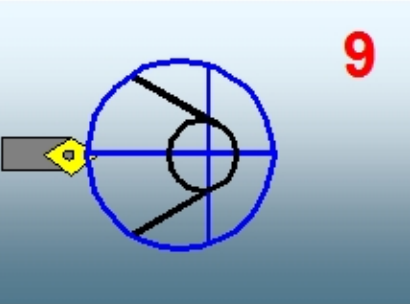
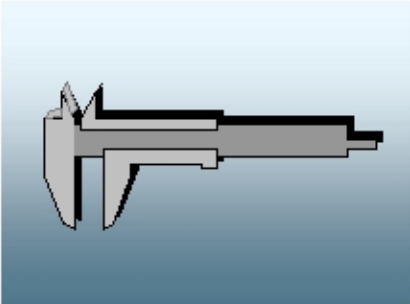
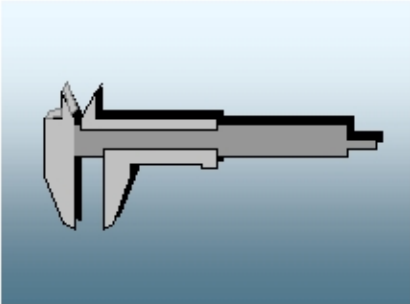
DATOS	Upper group 65692	Position 7	ID 65696	
847 - "collet chuck ER				
847				
	is Active ✓	Is Upper Group		
DATOS	Upper group 65692	Position 9	ID 65697	
849 - "holders misc.				
849				
	is Active ✓	Is Upper Group		
DATOS	Upper group 65637	Position 9	ID 65617	
9				
	is Active ✓	Is Upper Group		
DATOS	Upper group 65537	Position 10	ID 65577	
9 - other				
9				
	is Active ✓	Is Upper Group ✓		
DATOS	Upper group 65577	Position 1	ID 65650	
91 - measuring				
91				
	is Active ✓	Is Upper Group ✓		

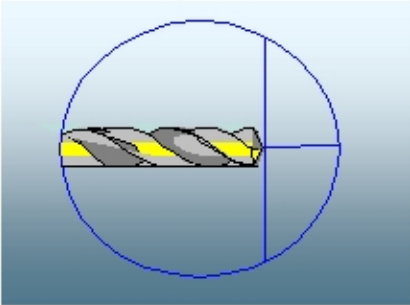
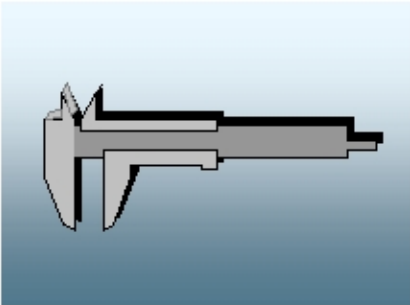
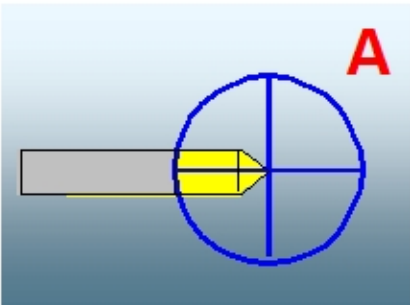
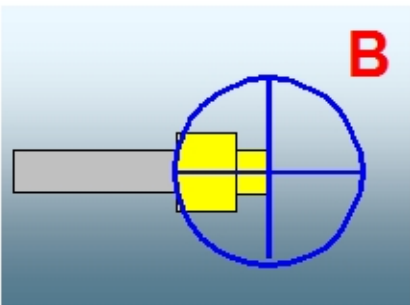
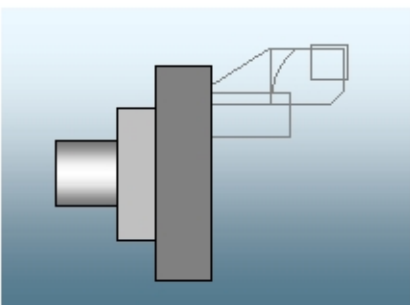

Group details

DATOS	Upper group 65650	Position 1	ID 65637	
911 - measure points				
911				
	is Active ✓	Is Upper Group ✓		
DATOS	Upper group 65650	Position 2	ID 65642	
912 - measure tools				
912				
	is Active ✓	Is Upper Group		
DATOS	Upper group 65644	Position 1	ID 65643	
A				
	is Active ✓	Is Upper Group		
DATOS	Upper group 65644	Position 2	ID 65645	
B				
	is Active ✓	Is Upper Group		
DATOS	Upper group 65676	Position 1	ID 65599	
Base plates modular systems				
	is Active ✓	Is Upper Group		

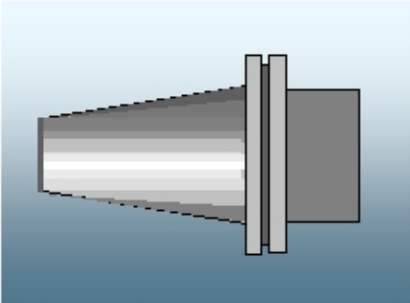
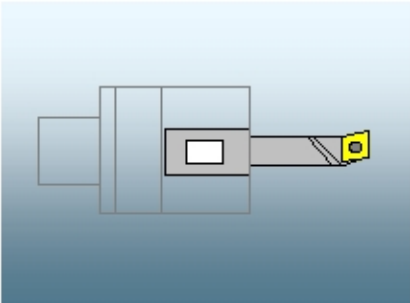
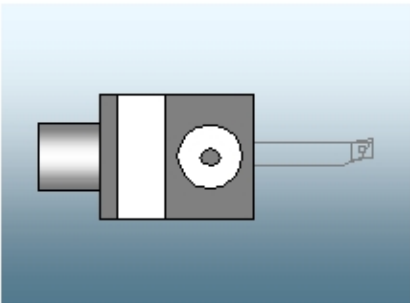
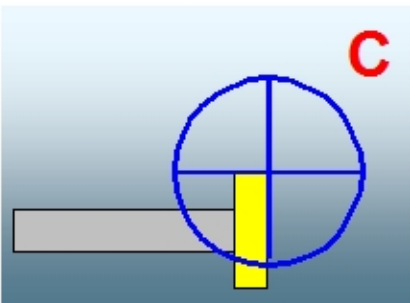
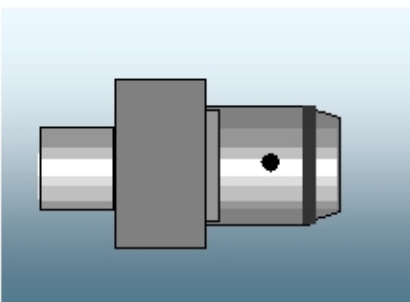
Group details

DATOS	Upper group 65582	Position 7	ID 65580	
Basic acceptions modular systems				
	is Active ✓	Is Upper Group		
DATOS	Upper group 65672	Position 2	ID 65589	
Boring bares and acceptions modular systems				
9.6				
	is Active ✓	Is Upper Group		
DATOS	Upper group 65672	Position 1	ID 65588	
Boring head modular systems				
9.4.7				
	is Active ✓	Is Upper Group		
DATOS	Upper group 65644	Position 3	ID 65646	
C				
	is Active ✓	Is Upper Group		
DATOS	Upper group 65582	Position 3	ID 65567	
Chucks for DIN 1835 B modular systems (Weldon)				
9.4.3				
	is Active ✓	Is Upper Group		

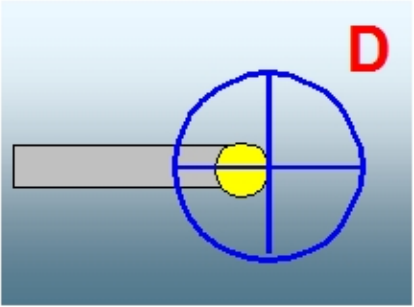
Group details

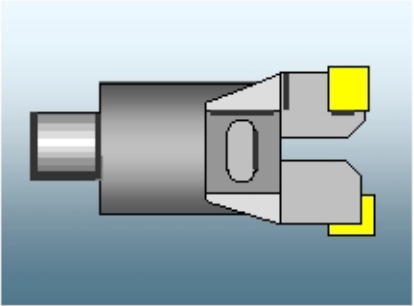
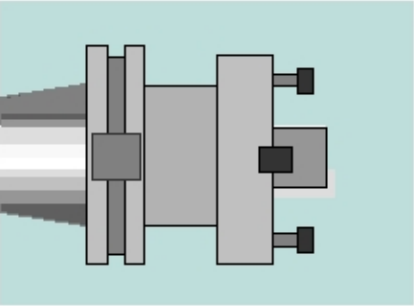
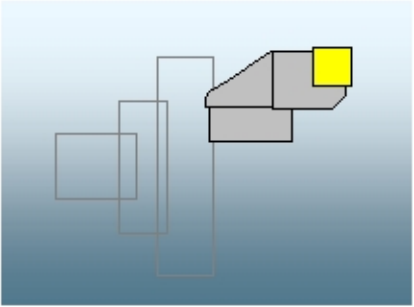
DATOS	Upper group 65644	Position 4	ID 65647	
D				
	is Active ✓		Is Upper Group	
DATOS	Upper group 65537	Position 1	ID 65537	
DATOS WinTool Common tools				
	is Active ✓		Is Upper Group ✓	
DATOS	Upper group 65676	Position 3	ID 65556	
Dual insert boring heads modular systems				
	is Active ✓		Is Upper Group	
DATOS	Upper group 65698	Position 10	ID 65570	
Face mill holders				
	is Active ✓		Is Upper Group	
DATOS	Upper group 65676	Position 2	ID 65590	
Insert holders modular systems				
	is Active ✓		Is Upper Group	

Group details

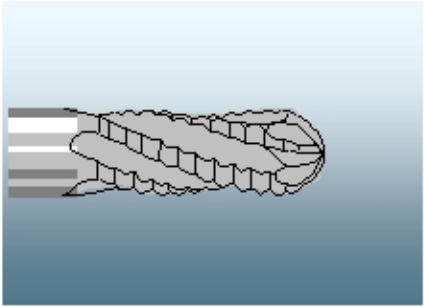
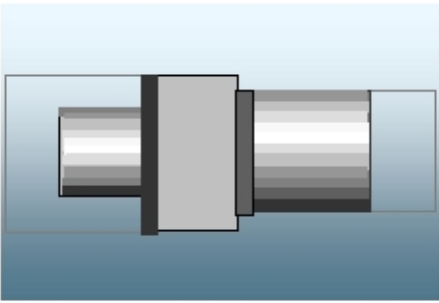
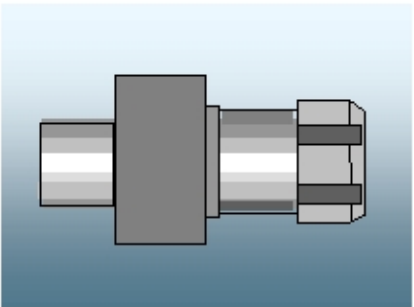
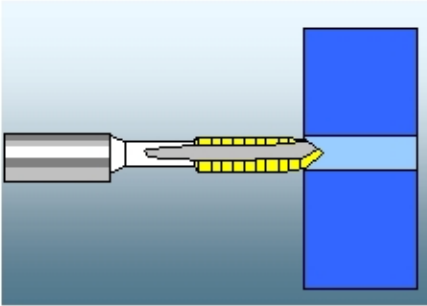
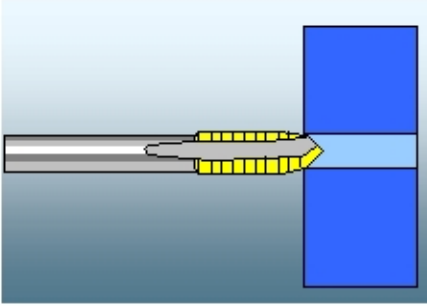
DATOS	Upper group 65539	Position 3	ID 65627	
Milling cutters DIN 845 (Morse taper)				
	is Active ✓		Is Upper Group	
DATOS	Upper group 65582	Position 6	ID 65572	
Reducers modular systems				
	is Active ✓		Is Upper Group	
DATOS	Upper group 65582	Position 2	ID 65585	
Spring collet chucks ER/ESX modular systems				
9.4.2				
	is Active ✓		Is Upper Group	
DATOS	Upper group 65656	Position 1	ID 65635	
Taps metric DIN 371				
	is Active ✓		Is Upper Group	
DATOS	Upper group 65656	Position 2	ID 65636	
Taps metric DIN 376				
	is Active ✓		Is Upper Group	

Group details

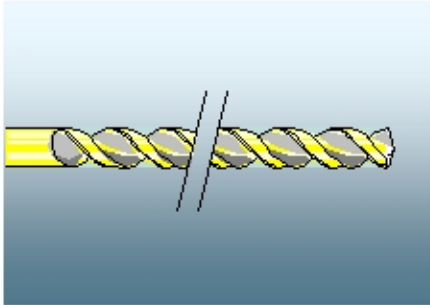
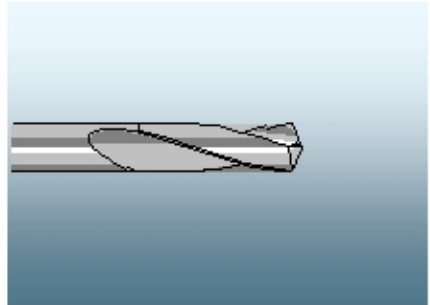
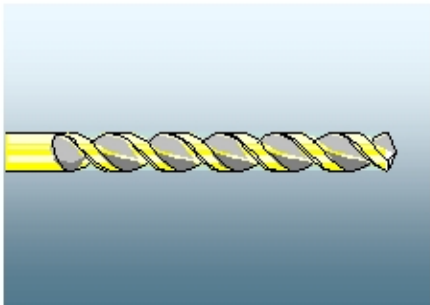
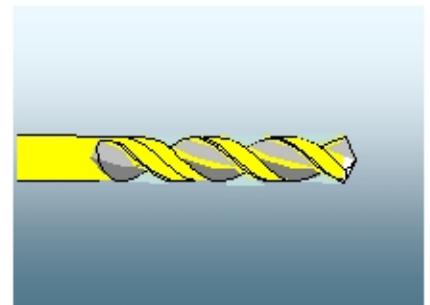
DATOS	Upper group 65651	Position 4	ID 65608	
Twist drills extra long DIN 1869 (cylindrical)	is Active ✓	Is Upper Group		
DATOS	Upper group 65651	Position 1	ID 65606	
Twist drills extra short DIN 1897 (cylindrical)	is Active ✓	Is Upper Group		
DATOS	Upper group 65651	Position 3	ID 65607	
Twist drills long DIN 340 (cylindrical)	is Active ✓	Is Upper Group		
DATOS	Upper group 65651	Position 2	ID 65560	
Twist drills short DIN 1897 (cylindrical)	is Active ✓	Is Upper Group		