

Common information

Descript thread plug gauge M06 x 1
 Design H6
 Sort
 Adapt

UID
 UNr 51310
 MID USR-51310
 Class Name A21 thread metric
 DIN Norm
 ISO Norm
 Code 17 QS OwnerNr 0
 Keyword PartsNr -32487
 GroupID PartsID -32487

Graphical data

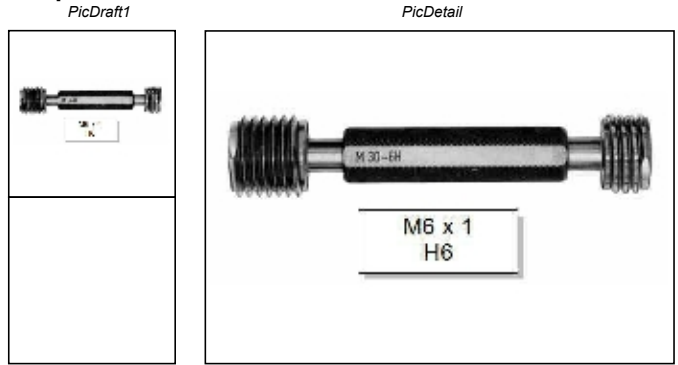

Part Pics ID -32487
 Name1 USR-51310
 Name2

Geometric data

DMC	6	CLength	1	CRadius	0	CFreeArc	0
DMNose	0	ZNose	0	Length	0	CMainArc	0
NeckDia		ZConflict	0	ZInfluence	0	CArc	0
DMConflict	0	UseLength		XInfluence	0	ArcInfluence	0
Sense	1	Teeth	0	AdjDM		AdjZ	
SpinDir	1	CWidth	0	DMMin	0	ZMin	0
SpinArc		Coolent		DMMax	0	ZMax	0
AdjArc		CenterCut		DMChange			

Matchcodes

MatchM1	Code	Mode	Shank	Cutting	Following	Mode	MatchCMin	MatchCMax
		1	0	1	1	1	0	0
				2		1	0	0
				3		1	0	0

Properties

Cutter		MultiC		Weight	0
AddOn	✓	Combi		Stability	0
NameGiving	✓	ZAdapt		SMax	0
Adapter		Synchro		NMMax	0
Clutch		NMControl		MeasurePoint	
Standard		Chip		NonMetric	

Additional information

UStock	1	UMin	0	UMDate	3/28/2011
UDisp	1	UQuant	0	USign	Admin
UPlace		UPrice	0		
UNorm		PackageSize	1		
UActiv	✓	WearPart			
How					

RC-State

ChangeDate
 State
 WinToolUser

InfoLink1 .\JPG\USR-51310.jpg

InfoLink2

