

Technical Datasheet

Common Information

Descript PARLEC_C40-32ER312
Design ER 32 COLLET HOLDER
Sort 3"GAGE LENGTH
Adapt MAS/CAT40

UID
UNr 10009
MID C4032ER312
Class Name 812- COLLET HOLDERS
DIN Norm
ISO Norm

Code 9 MHX *OwnerNr* 0
KeyWord CAT40 ER32 *PartsNr* -32384
GroupID *PartsID* -32384

Graphical Data

PicDraft1

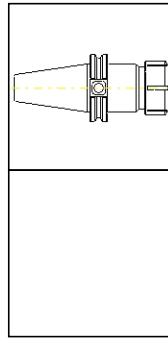

PicDetail

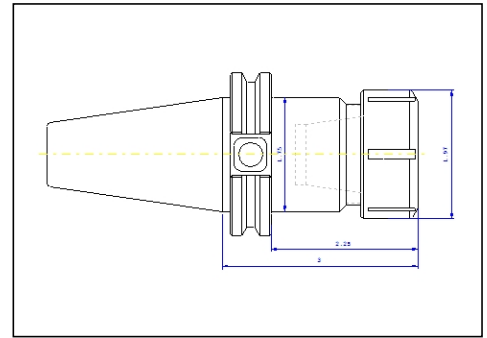

Part Pics ID -32383
Name1 C4032ER312
Name2

Geometric Data

<i>DMC</i>	1.97	<i>CLength</i>	0	<i>CRadius</i>	0.03	<i>CFreeArc</i>	0
<i>DMNose</i>	0	<i>ZNose</i>	0	<i>Length</i>	5.69	<i>CMainArc</i>	0
<i>NeckDia</i>	1.75	<i>ZConflict</i>	2.25	<i>ZInfluence</i>	3	<i>CArc</i>	0
<i>DMConflict</i>	1.75	<i>UseLength</i>	0	<i>XInfluence</i>	0	<i>ArcInfluence</i>	0
<i>Sense</i>	1	<i>Teeth</i>	0	<i>AdjDM</i>		<i>AdjZ</i>	
<i>SpinDir</i>	1	<i>CWidth</i>	0	<i>DMMin</i>	0	<i>ZMin</i>	0.88
<i>SpinArc</i>	0	<i>Coolent</i>		<i>DMMax</i>	0	<i>ZMax</i>	1.2
<i>AdjArc</i>		<i>CenterCut</i>		<i>DMChange</i>			

Matchcodes

<i>MatchM1</i>	<i>Code</i>	<i>Mode</i>	<i>Shank</i>	<i>Cutting</i>	<i>Following</i>	<i>Code</i>	<i>Mode</i>	<i>MatchCMin</i>	<i>MatchCMax</i>
66417	SK40-CAT-I	1	0	1	65604	SPZ ESX/ER-32	2	0	0
				2			1	0	0
				3			1	0	0

Properties

<i>Cutter</i>		<i>MultiC</i>		<i>Weight</i>	0
<i>AddOn</i>		<i>Combi</i>		<i>Stability</i>	0
<i>NameGiving</i>		<i>ZAdapt</i>		<i>SMax</i>	0
<i>Adapter</i>	✓	<i>Synchro</i>		<i>NMMax</i>	0
<i>Clutch</i>		<i>NMControl</i>		<i>MeasurePoint</i>	
<i>Standard</i>	✓	<i>Chip</i>		<i>NonMetric</i>	✓

Additional Information

<i>UStock</i>	0	<i>UMin</i>	0	<i>UMDate</i>	4/10/2007
<i>UDisp</i>	0	<i>UQuant</i>	0	<i>USign</i>	Admin
<i>UPlace</i>		<i>UPrice</i>	0		
<i>UNorm</i>		<i>PackageSize</i>	1		
<i>UActiv</i>	✓	<i>WearPart</i>			
<i>How</i>					

RC-State

ChangeDate
State
WinToolUser

InfoLink1

InfoLink2

DATOS